

## WitGood Intelligent Weighing System Controller

### INSTRUCTION MANUAL

Applicable to EF-7200, EF-7300, EF-7900 Series

## 1 Device Overview and Identification

The EF-7900 intelligent weighing system is a high-capacity electronic scale designed specifically for the livestock breeding industry. This device not only displays load weights in real time but also tracks and records the amounts of feed and discharge. Additionally, it provides immediate access to historical feed consumption data and performs data analysis.

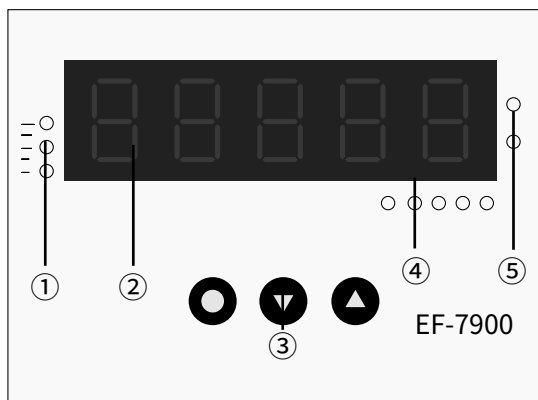

① Communication Signal Indicator    ② Display Area    ③ Key

④ Additional Indicators    ⑤ Feeding and Discharging Indicator

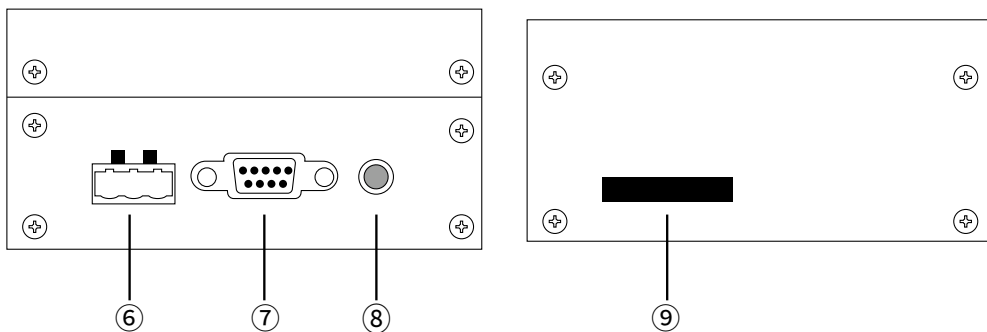

⑥ DC9-14V Power Input Interface    ⑦ E4MCP Special Interface interface

⑧ Communication Module Antenna Interface    ⑨ SIM Card Connector

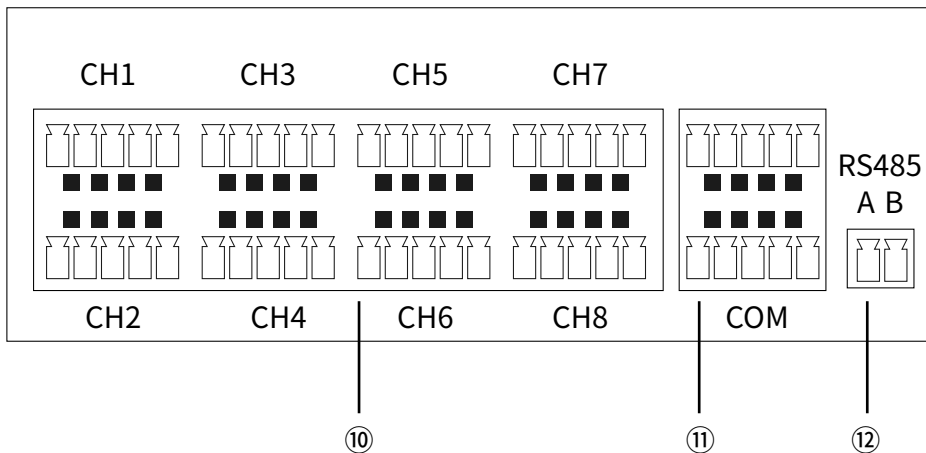

- (1) ⑩ Interfaces CH1 through CH8 are designated for the load cell, arranged from left to right.

Pin	Explanation	Instrument Identification
1	Load cell signal input positive	S+
2	Load cell signal input negative	S-
3	Load cell power supply negative	E-
4	Load cell power supply positive	E+
5	Load cell shielding ground	G

Table 1

(2) ⑪ This part features both digital and analog signal input and output ports. For digital outputs, O1 and O1-COM, as well as O2 and O2-COM, serve as paired interfaces. Digital inputs are managed through I1 and I1-COM, and I2 and I2-COM pairs. For analog signals, AI accepts inputs ranging from 0 to 20mA, while GI is designated for negative analog inputs.

(3) ⑫ The RS485 communication interface includes A-RS485 for the positive signal and B-RS485 for the negative signal.

## 2 Intelligent Weighing Controller Operations

### 2.1 Startup Procedures

Upon startup, the instrument displays "99999-00000" as part of its self-inspection process. After completing the self-check, it transitions to the weighing mode and displays the current real-time weight.

### 2.2 Load cell Configuration



Figure 1



Figure 1

Figure 1: Load cell Setting Display 1.CGEN

Figure 2: Load cell Setting Display 1-C11

Note: Long press: press and hold the button for 2s  
Short press: press and hold the button for 1s

Step	Operation	Display	Explanation
1	Long press the 【○】 key in the real-time weight display interface for 2S	As shown in Figure 1	
2	Short press the 【○】key	As shown in Figure 2	Display sensor status
3	Short press the 【▲】 or 【▼】 key	Cyclically display 1-8 load cell status	
4	Long press the 【○】 key for 2S	Figure 2 The last bit starts flashing	Flashing indicates that the load cell can be set to be valid or invalid
5	Short press the 【▲】or 【▼】key	As shown in Figure 2, the last digit displays 0 or 1The rest remains unchanged	0 means the load cell is invalid, 1 means the load cell is valid
6	Long key【○】key 2S	As shown in Figure 2, the last bit does not flash	Exit the load cell setting of this position; Repeat steps 3-6 to set all load cells.
7	Short press【○】	As shown in Figure 1	
8	Long press the【○】key for 2S	Back to Live Show Meet	

## 2.3 Manual Zero Adjustment



Figure 3

As shown in Figure 3, 2. ZERO: manual zero setting function

Step	Operation	Display	Explanation
1	Long press the [○] key in the real-time weight display interface for 2S	As shown in Figure 1	
2	Short press the [▲] or [▼] key	As shown in Figure 3	Press the key to turn pages to the display interface shown in Figure 3
3	Short press [○]	Initially displays "00000"; previous zero-point weights are shown if set.	
4	Long press the [○] key for 2S	Initially displays "00000"; previous zero-point weights are shown if set.	The first digit starts flashing, and the flashing digit size can be set

Step	Operation	Display	Explanation
5	Short press【○】	Initially displays "00000"; previous zero-point weights are shown if set.	Flash to the next bit, press 【○】key for a short time to flash in turn, and which bit flashes means that this bit can be set
6	Short press the 【▲】or 【▼】key	Initially displays "00000"; previous zero-point weights are shown if set.	Set the required weight figure size
7	Long press the【○】key for 2S	Display the currently set weight value	End zero-point weight setting and stop the display from flashing.
8	Short press【○】	As shown in Figure 3	
9	Long key【○】	Return to the real-time weight display interface	



### 2.3.1 View the last feeding weight

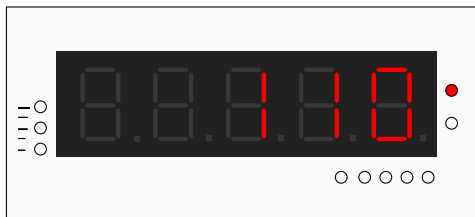

Figure 4

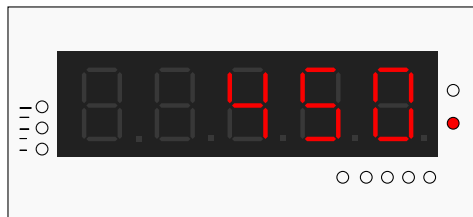

Figure 5

Step	Operation	Display	Explanation
1	Short press the【▲】key	The weight of last feeding is shown in Figure 4	The feeding indicator is always on
2	Short press the【▼】key	The weight of last feeding is shown in Figure 5	The discharge indicator is always on
3	Short press【○】	Realtime weight	The feeding or discharging indicator lights are off.

## 2.4 General Indicators

- (1) UP and DN Indicators Off: Displays the current real-time weight.
- (2) UP Indicator On: Shows the weight from the last feeding, as depicted in Figure 4.
- (3) DN Indicator On: Displays the weight from the last discharge, as depicted in Figure 5.
- (4) UP Indicator Flashing: Indicates that feeding is in progress.
- (5) DN Indicator Flashing: Indicates that a discharge is in progress.
- (6) O1 Indicator On: The first digital output signal is activated.
- (7) O2 Indicator On: The second digital output signal is activated.
- (8) I1 Indicator On: The first digital input signal is activated.
- (9) I2 Indicator On: The second digital input signal is activated.
- (10) AI Indicator On: All analog signal inputs are being detected.

## 2.5 Signal Indication of Communication Module

- (1) Single Indicator On: Signal strength is weak.
- (2) Two Indicators On: Signal strength is medium.
- (3) All Indicators On: Signal strength is strong.

- (4) All Slow Flashes (every 1s): No SIM card inserted.
- (5) All Quick Flashes (every 0.1s): SIM card present and registering.
- (6) Flashing Last Lit Indicator: Server connection in progress.
- (7) Indicator Constantly On: Connection to the server is successful.
- (8) Last Indicator On, Brief Flash: Communicating with the server.